

Scharnier
Maßstab: 1:1

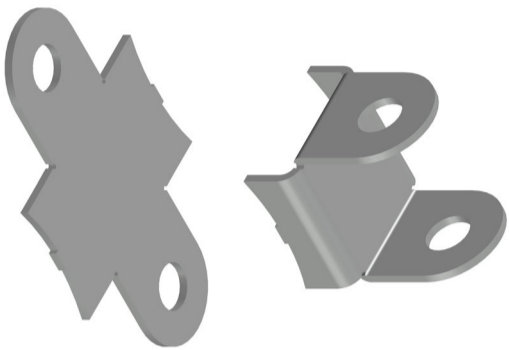

Klappe
Maßstab: 1:2

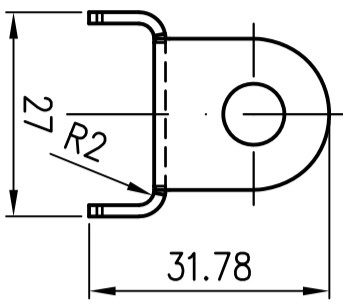
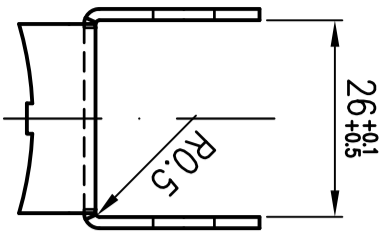
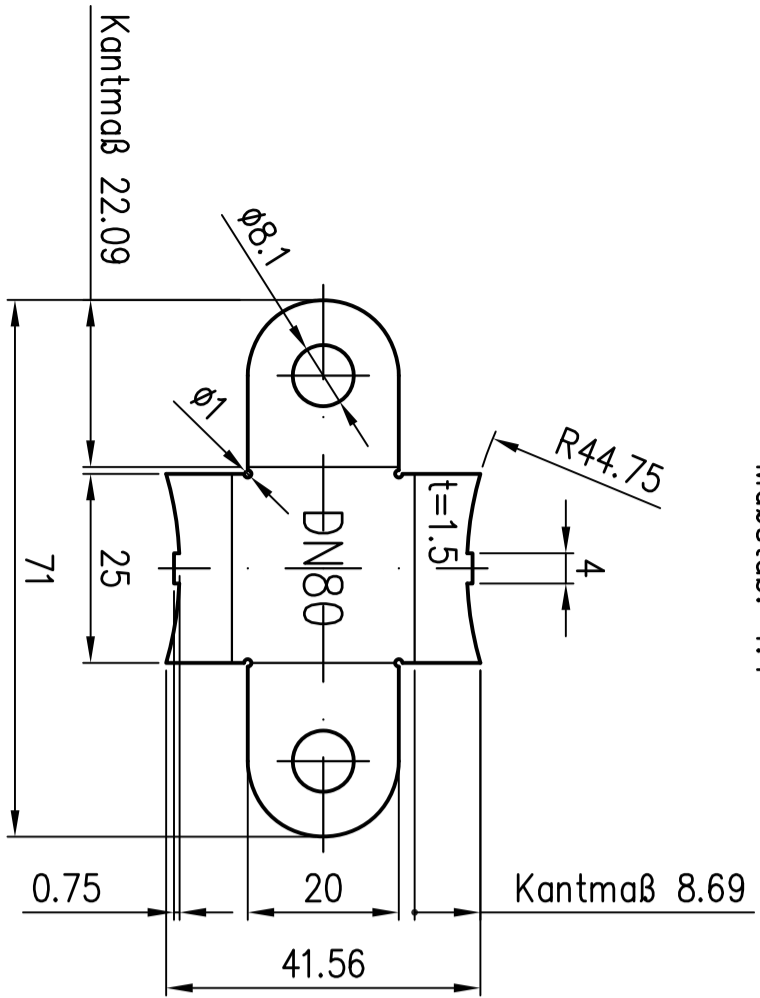
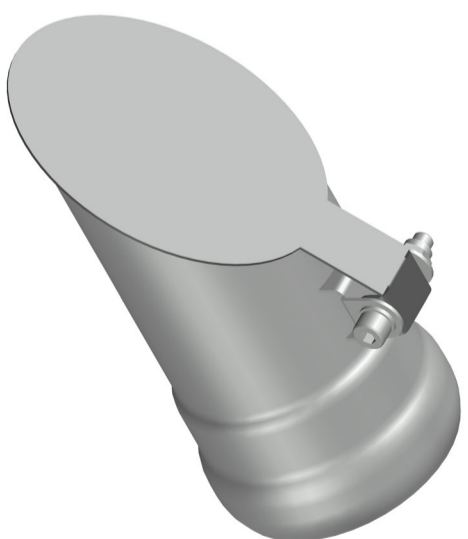
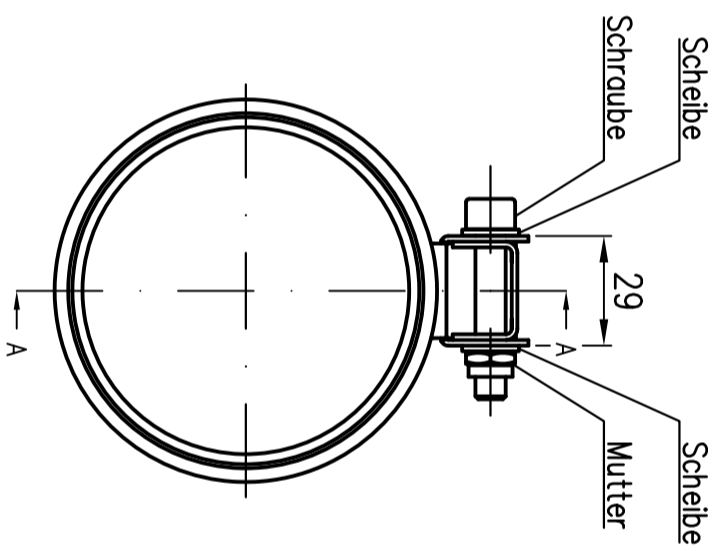
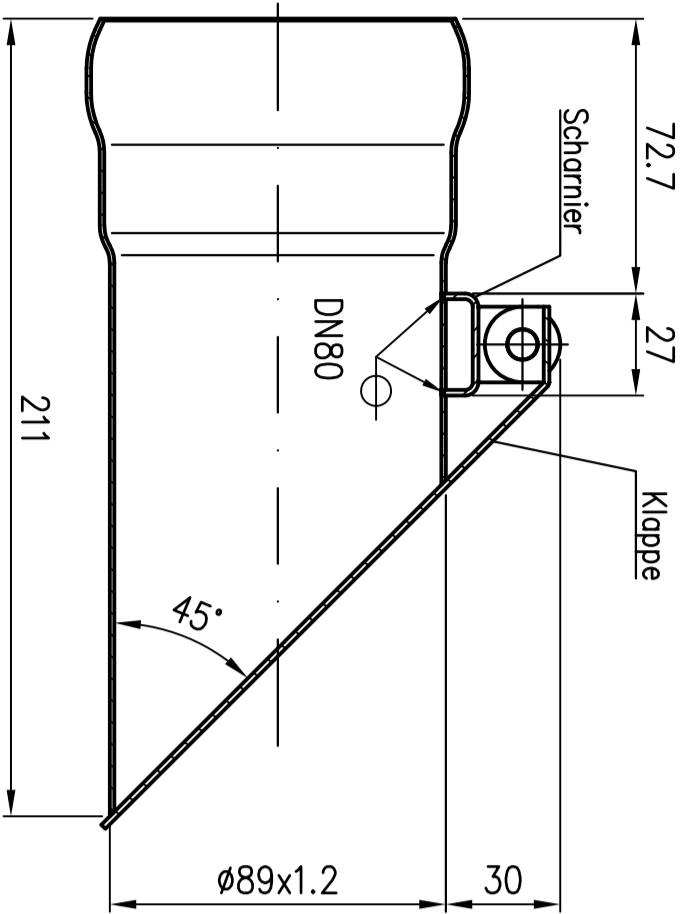
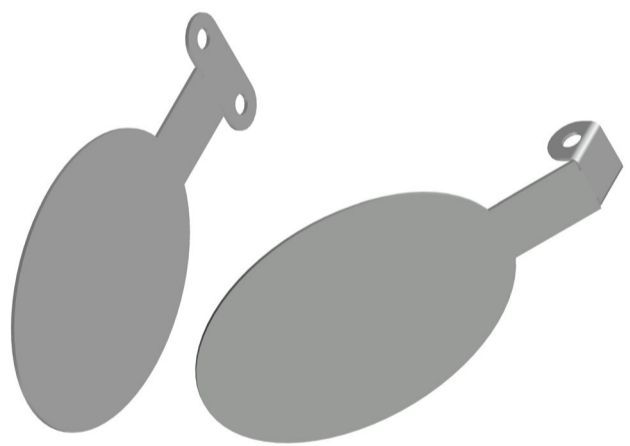
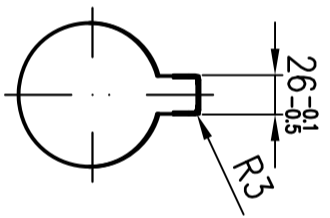
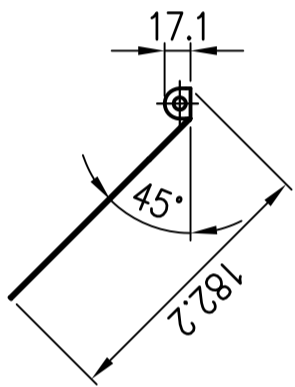
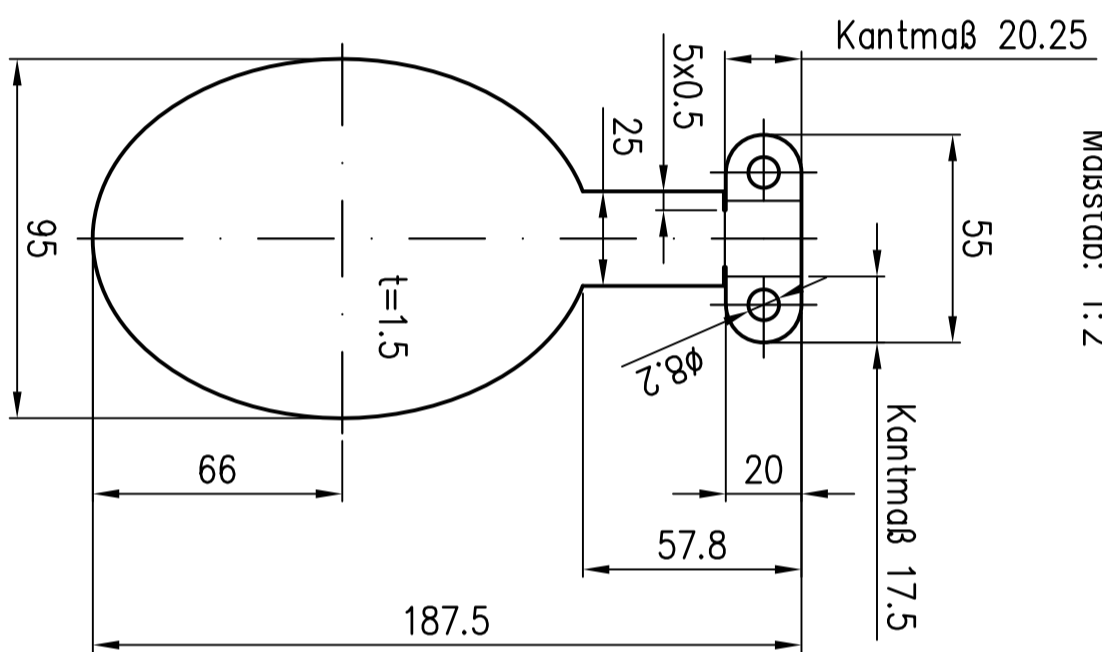

Zubehör:
1x Zylinderkopfschraube mit Innensechskant ISO 4762 M8x45 A2
2x Scheibe ISO 7090 8 A2
1x Sechskantmutter, selbstsichernd ISO 10511 M8 A4

Werkstoff: Blech: 1.4301 Rohr: 1.4404		Zul. Abw. ISO 2768-m DIN EN 1124-3		Benennung Froschkloppel DN80		Zeichnungs-Nr. 04320.080X	
Maßstab 1:2		Gez. 23.10.		Name Rudolph		Ersatz für:	
2018		Tag		Name		Ersatz durch:	
Gez.		23.10.		Rudolph		ersetzt durch:	
Norm.		14.11.18		Schm.		04320.080X.DWG	
Index		Änderung		Tag		Name	
Index		Änderung		Tag		Name	

