

Scharnier
Maßstab: 1:1

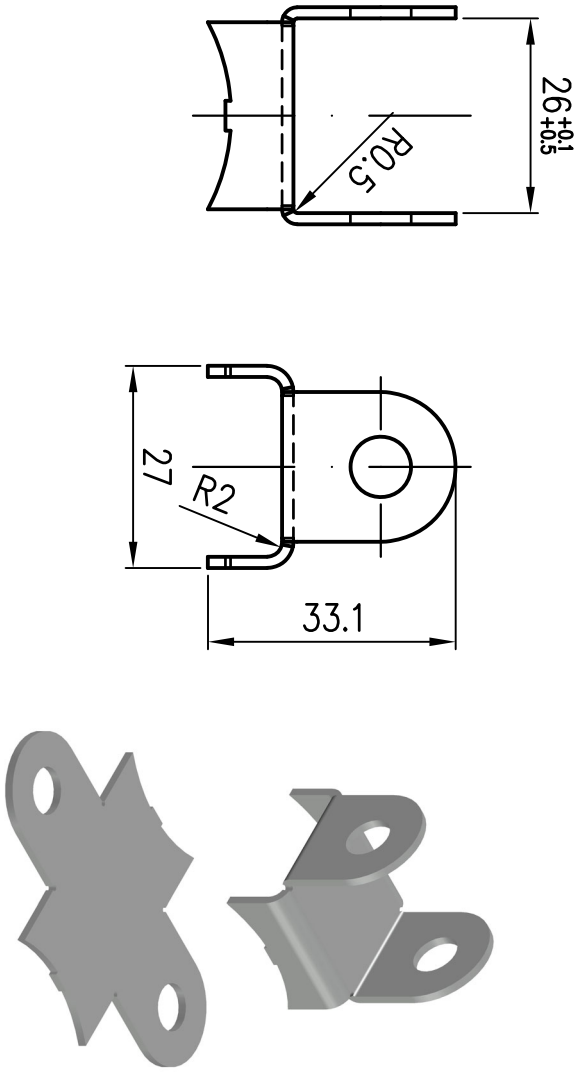

Klappe
Maßstab: 1:2

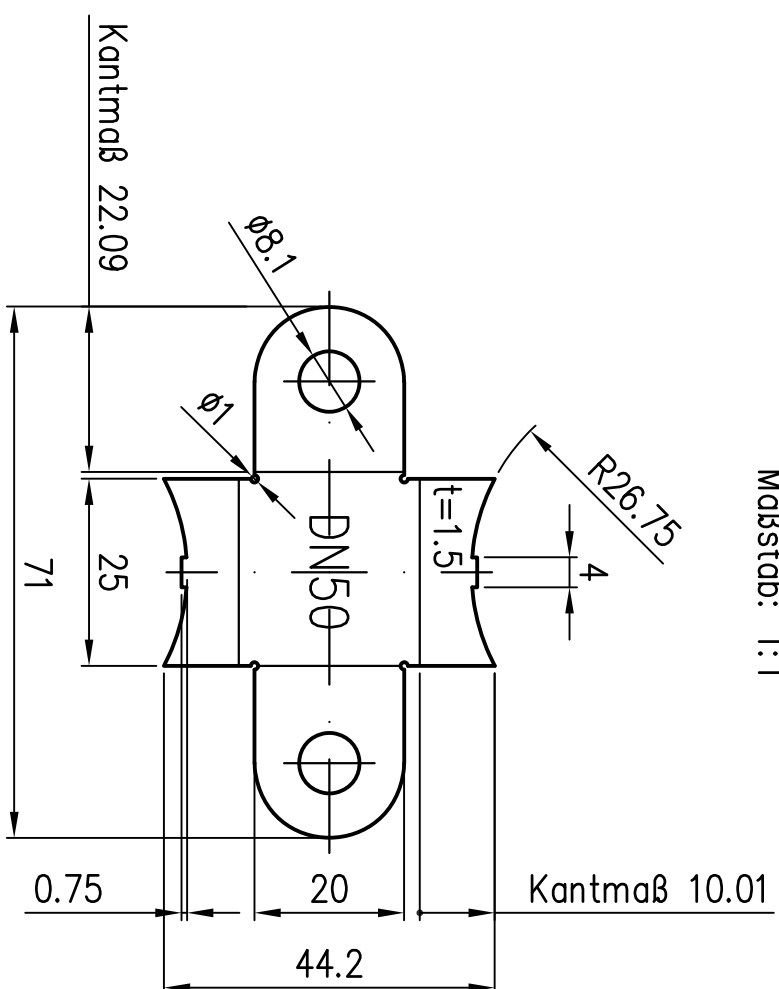
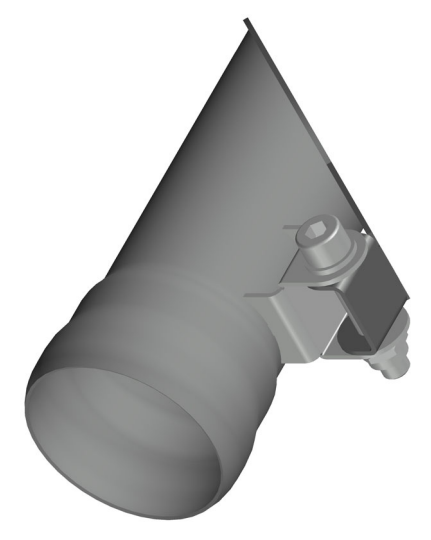
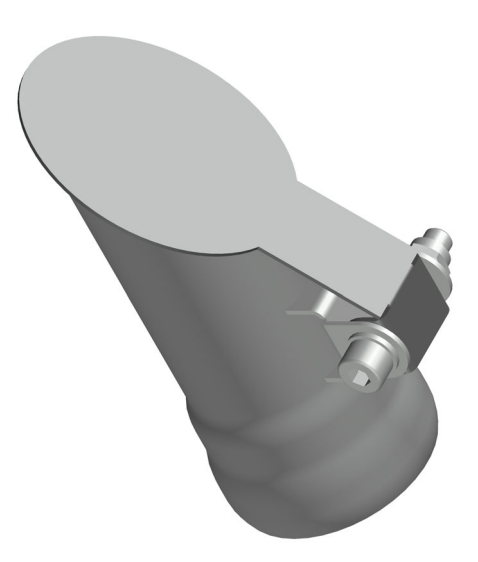
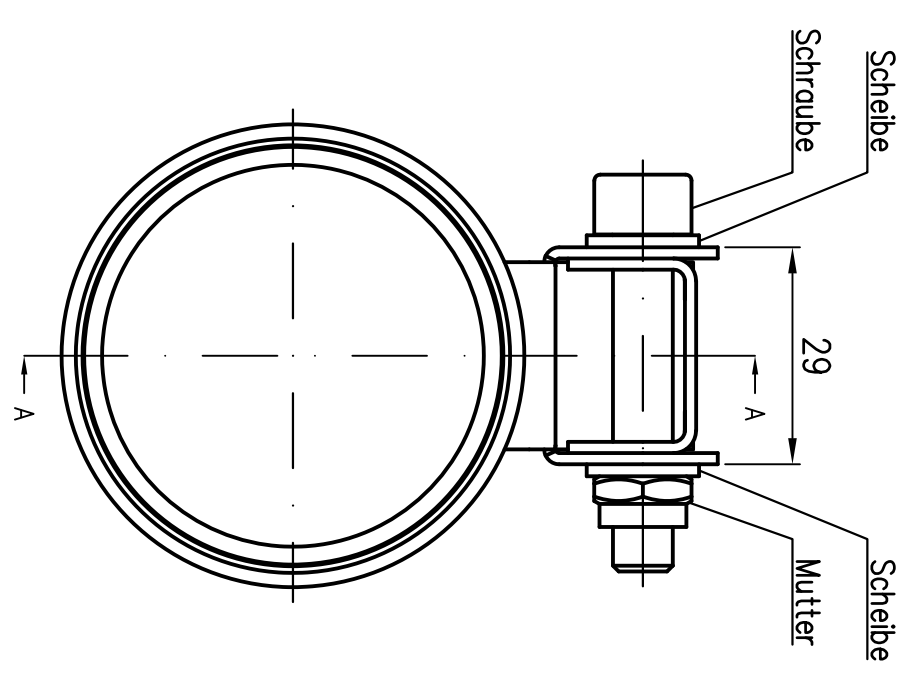
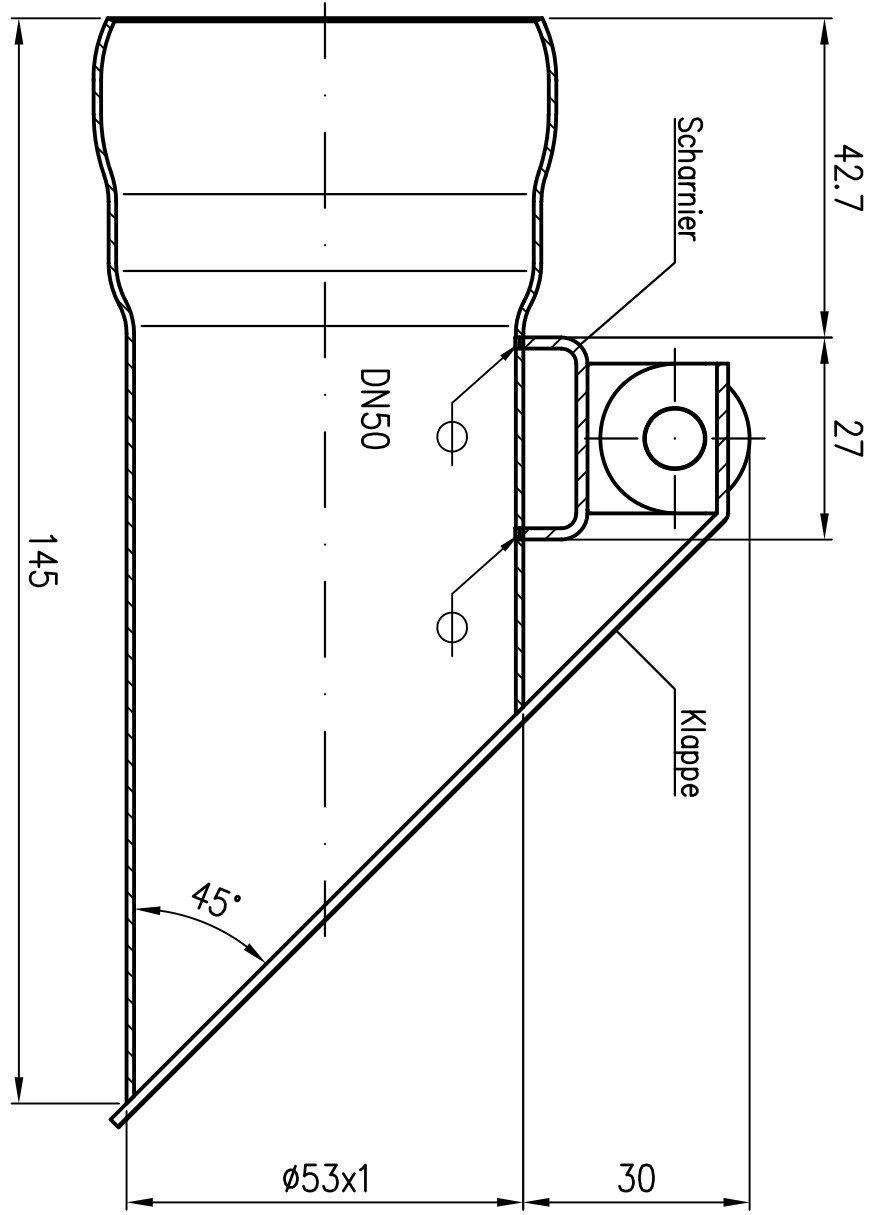
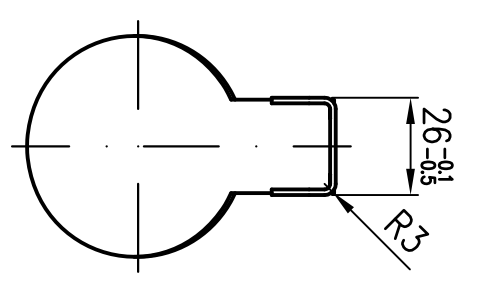
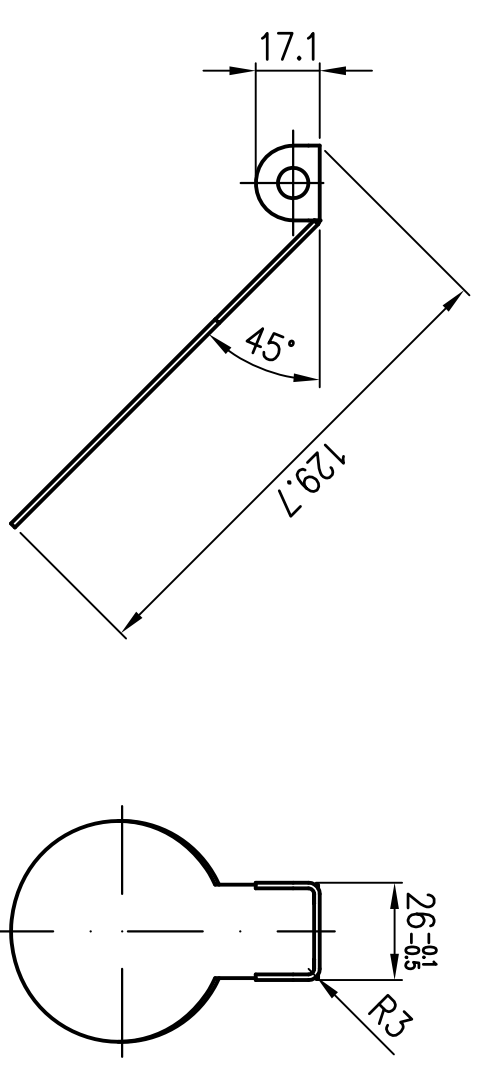
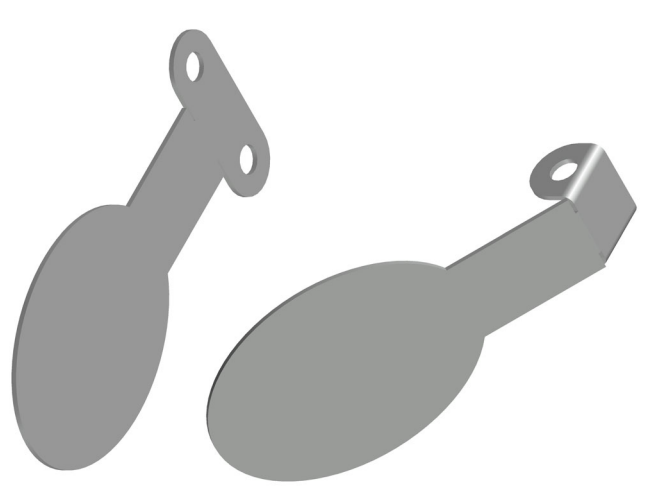
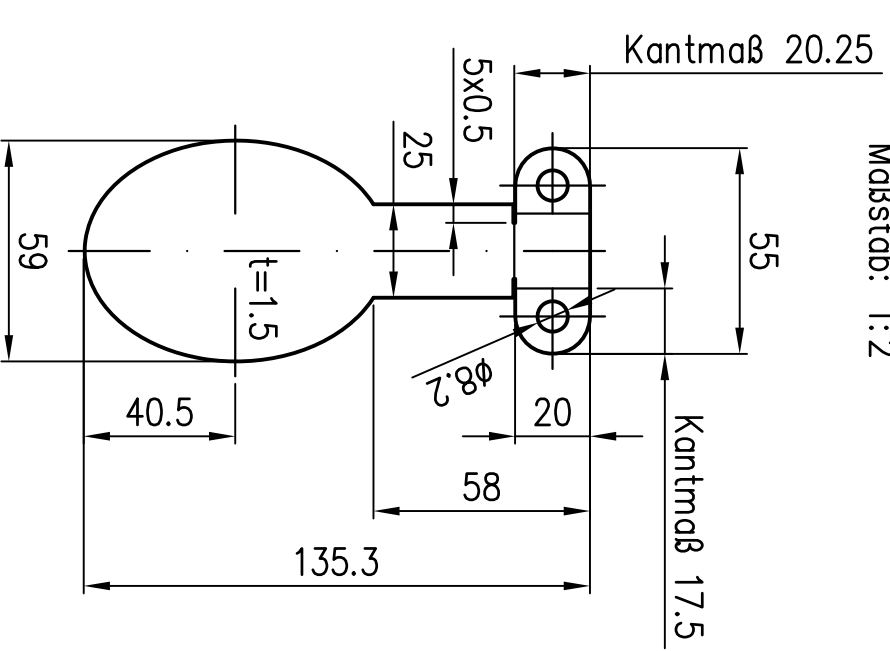

Zubehör:
 1x Zylinderkopfschraube mit Innensechskant ISO 4762 M8x45 A2
 2x Scheibe ISO 7090 8 A2
 1x Sechskantmutter, selbstsichernd ISO 10511 M8 A4

Index		Werkstoff: 1.4301		Benennung Froschklappe DN50		Zeichnungs Nr. 04320.050X	
Änderung		Maßstab 1:1		Zul. Abw. ISO 2768-m DIN EN 1124-3		Ersatz für:	
Tag		2018		Name Rudolph		EDV-Art.Nr. 04320.050X	
Name		Gez. 23.10.		He		ersetzt durch:	
		Gepf. 10.11.18		Schm.		Bauvorhaben	
		Norm. 14.11.18		Schm.			
		Logo					